

Ion Exchange

Chuck Babb

Hytek Finishing Co.

Chemist

cbabb@hytekfinishes.com

253.872.7160

Greg Allan

Advanced Chemical Technologies

Consultant

allan_adv_chem@msn.com

425.868.7804

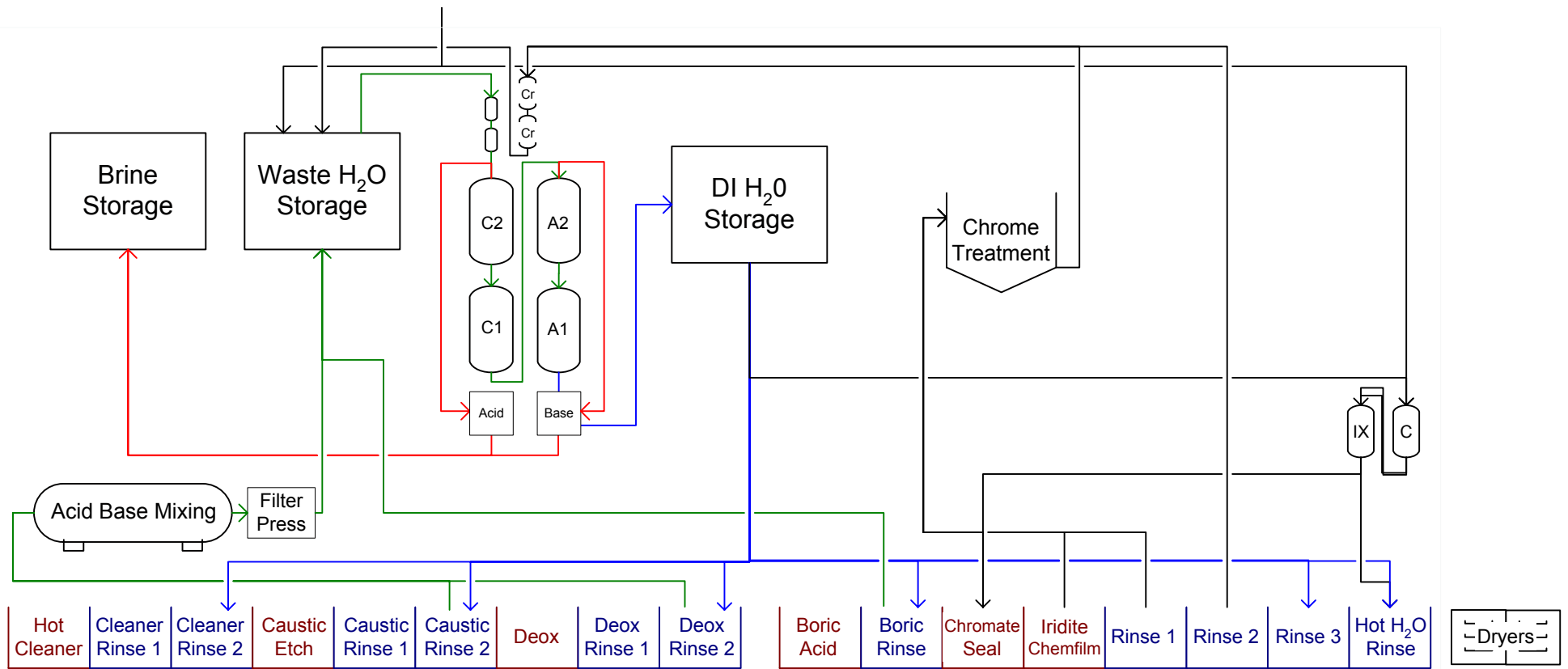

Equipment

Process Bath

Rinse Bath

Pipelines

Clean Water

Dirty Water

Regenerant

Chrome

City Water



- Opened January 1998
- Managed by Hytek Finishes, Kent, WA
- Supports Boeing Co.
- Aluminum Processes:
 - Boric-Sulfuric Anodize
 - Chromate Conversion
 - Penetrant Inspection
 - Painting

Hytek

Introduction



Hytek

Essentials for Success



Hytek

Dragout Reduction: Racking



Hytek

Dragout Reduction: Hang Time



Hytek

Dragout Reduction: Spray Rinsing



Hytek

Bath Testing



Hytek

Bath Maintenance



Hytek

Process Bath Treatment / Disposal

- Concentrated solutions
- Treated on-site or shipped off-site

Hytek

Chrome Water



Chromium Specific
Ion Exchange Columns

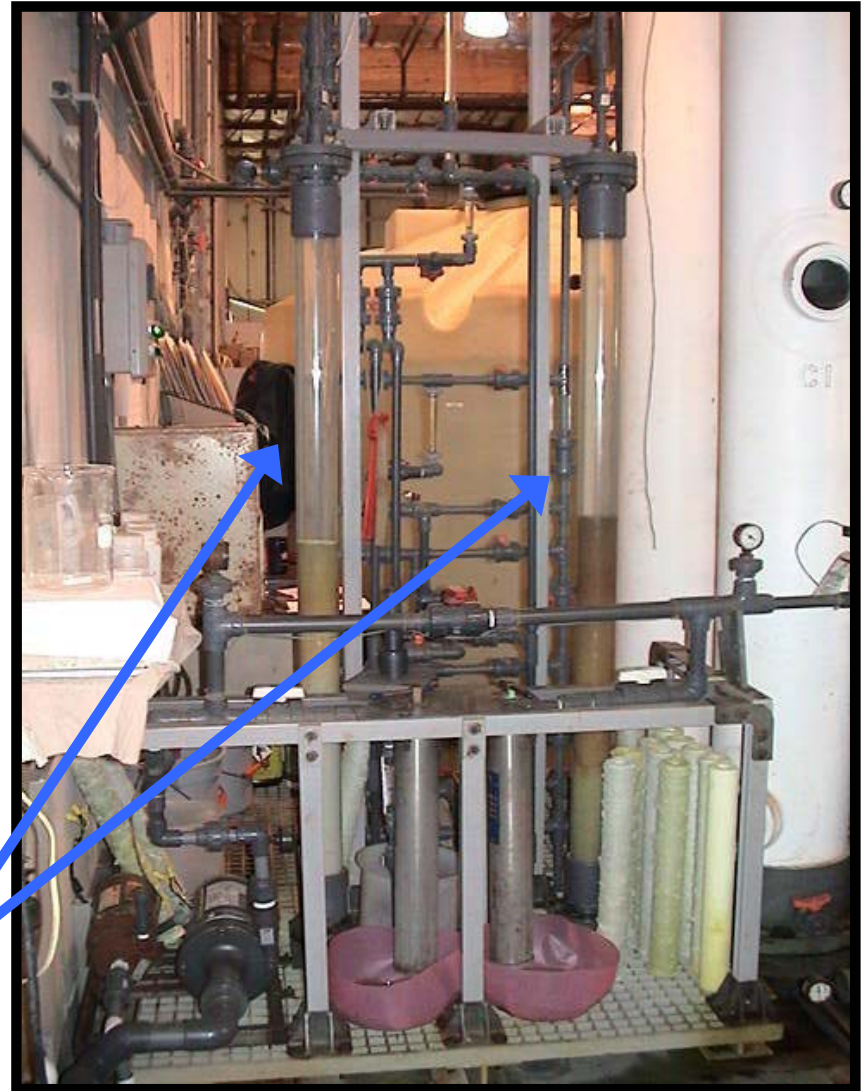

Hytek

Ion Exchange System



Hytek

Ion Exchange Water Flow

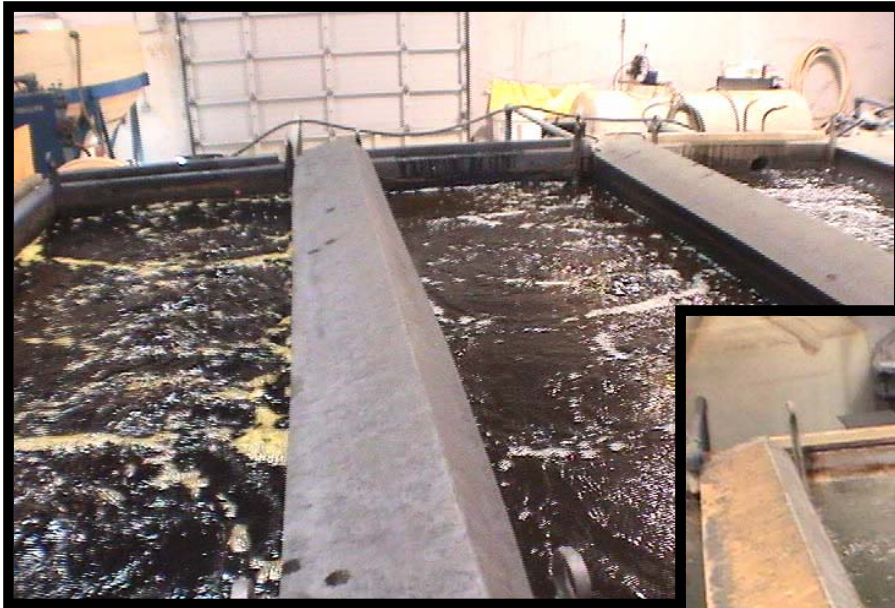

Hytek

Ion Exchange Pretreatment

Acid / Base
Mixing Tank



Hytek

Ion Exchange Pretreatment



Filtration Casing



Filter Cartridge
Cleaning

Hytek

Ion Exchange Pretreatment



Hytek

Ion Exchange Columns

Anion Resin



Cation Resin



Hytek

Ion Exchange Monitoring



Hytek

Ion Exchange Design

Sight Glass

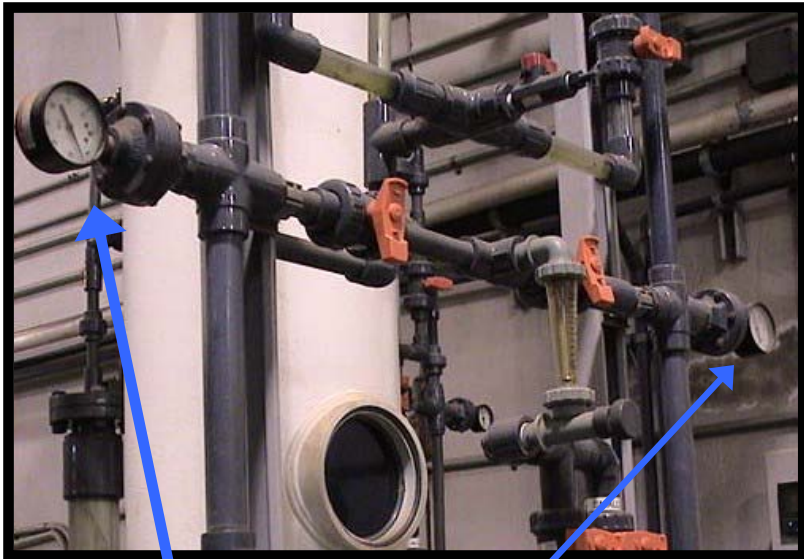

Pressure Gauges

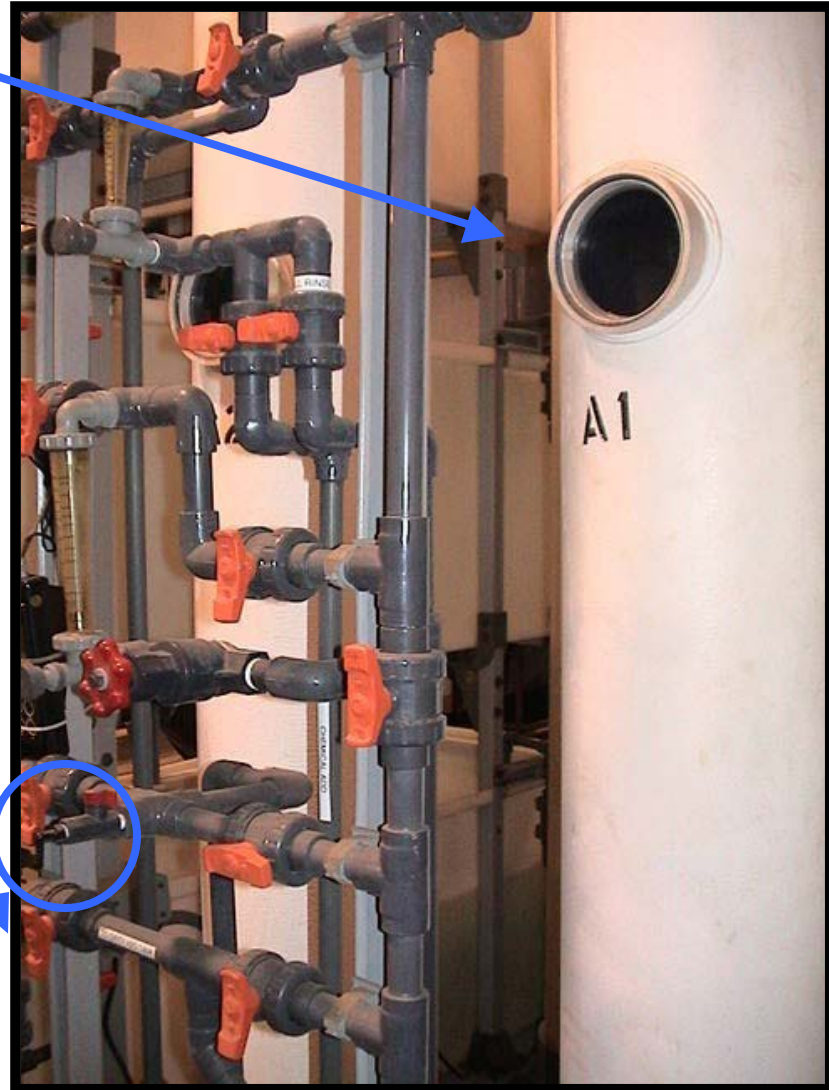

Sample Valve

Hytek

Ion Exchange Regeneration

Acid

Base

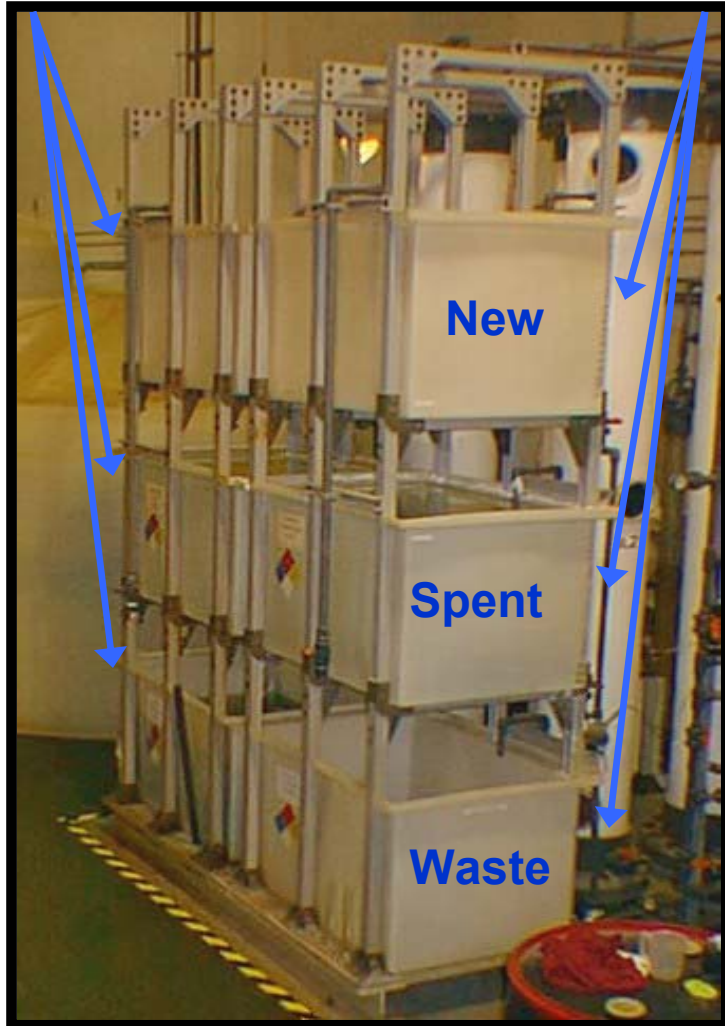

Brine Storage

Hytek

Ion Exchange Regeneration



Esterline **HYTEK**
The Leader In High Technology Surface Finishing
EVERETT



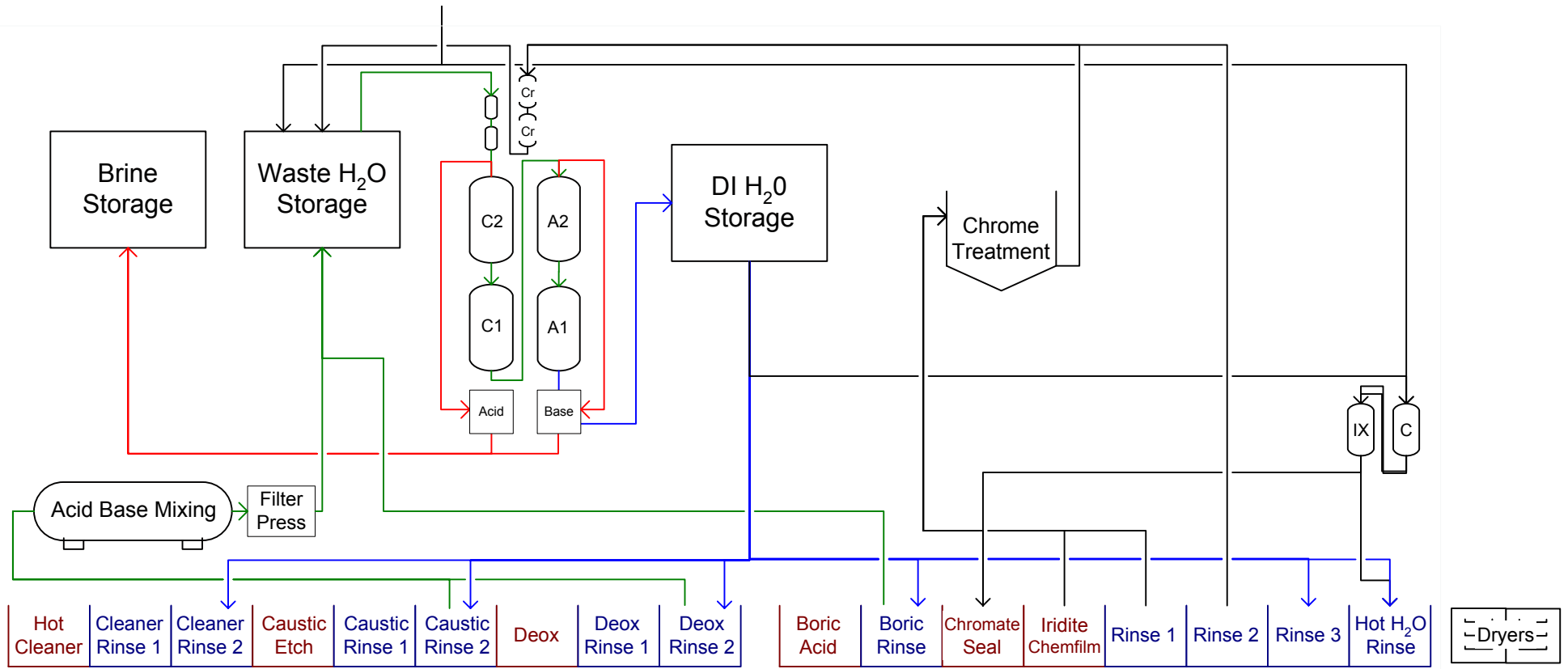

Equipment

Process Bath

Rinse Bath

Pipelines

Clean Water

Dirty Water

Regenerant

Chrome

City Water